



quick & easy

Router Table

This simple table is easy to build, transport, and stow away at the end of the day.

This router table is packed with some impressive features. But what I really like about it is that it takes only one 5' x 5' sheet of 1/2" Baltic birch plywood (see the cutting diagram on the next page) and a weekend to build.

LARGE TOP. Fast, inexpensive construction isn't the only thing going for this router table. For starters, the top measures a full 20" x 32". But there's more to it than size. For example, the top tilts up for easy router access to change bits and make height adjustments. And the heavy-duty fence makes accurate

cuts a snap. It takes no effort at all to adjust it quickly and lock it securely to the tabletop.

SIMPLE JOINERY. The case is built with simple, no-frills joinery. You can make all the parts with nothing more than a table saw and drill press. Rabbits, dadoes, and butt joints create a strong cabinet that stands up to hard use.

PORTABLE CONVENIENCE. On the job site or in your shop, this router table can be quickly clamped to a workbench or even sawhorses. And there's a drawer at the bottom for storing bits, wrenches, and other items.

CONSTRUCTION DETAILS

OVERALL DIMENSIONS: 20" L x 32" W x 14 1/4" H

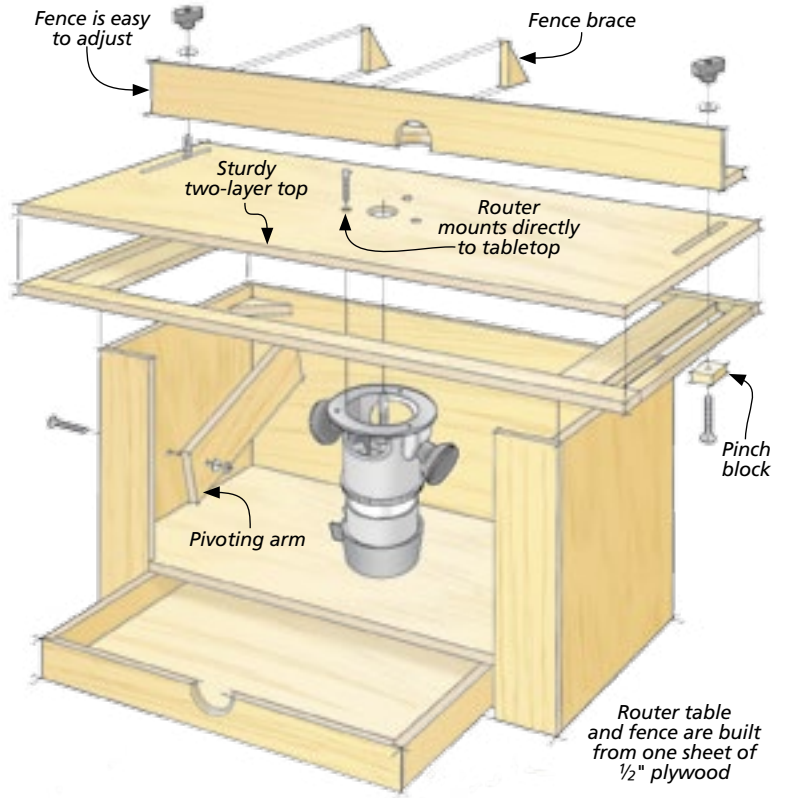
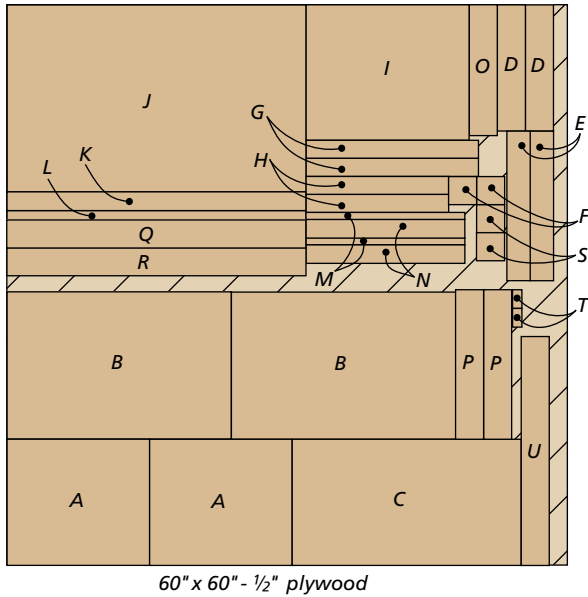

Materials, Supplies & Cutting Diagram

CASE

A	Sides (2)	1/2 ply - 13 1/2 x 15 1/4
B	Bottom/Divider (2)	1/2 ply - 15 3/4 x 24
C	Back (1)	1/2 ply - 13 1/2 x 24 1/2
D	Front Stiles (2)	1/2 ply - 3 x 13 1/2
E	Drawer Guides (2)	1/2 ply - 15 1/4 x 2 1/2
F	Corner Blocks (4)	1/2 ply - 2 1/2 x 2 1/2

DRAWER

G	Front/Back (2)	1/2 ply - 1 15/16 x 18 7/16
H	Sides (2)	1/2 ply - 1 15/16 x 15 1/4
I	Bottom (1)	1/2 ply - 14 1/2 x 17 7/16

TOP

J	Top (1)	1/2 ply - 20 x 32
K	Front Brace (1)	1/2 ply - 2 x 32
L	Back Brace (1)	1/2 ply - 1 x 32
M	Side Braces (2)	1/2 ply - 3/4 x 17
N	Side Fillers (2)	1/2 ply - 2 x 17
O	Arm (1)	1/2 ply - 3 x 13

FENCE

P	Inner Faces (2)	1/2 ply - 3 x 16
Q	Outer Face (1)	1/2 ply - 3 x 32
R	Base (1)	1/2 ply - 3 1/2 x 32
S	Braces (4)	1/2 ply - 2 1/2 x 2 1/2
T	Pinch Blocks (2)	1/2 ply - 1 x 2

- (1) Nickel-plated Piano Hinge w/Screws
- (1) 1/4" Flat Washer
- (1) 1/4" Lock Nut
- (2) 5/16" x 2" Carriage Bolts
- (2) 5/16" Flat Washers
- (2) 5/16" T-knobs

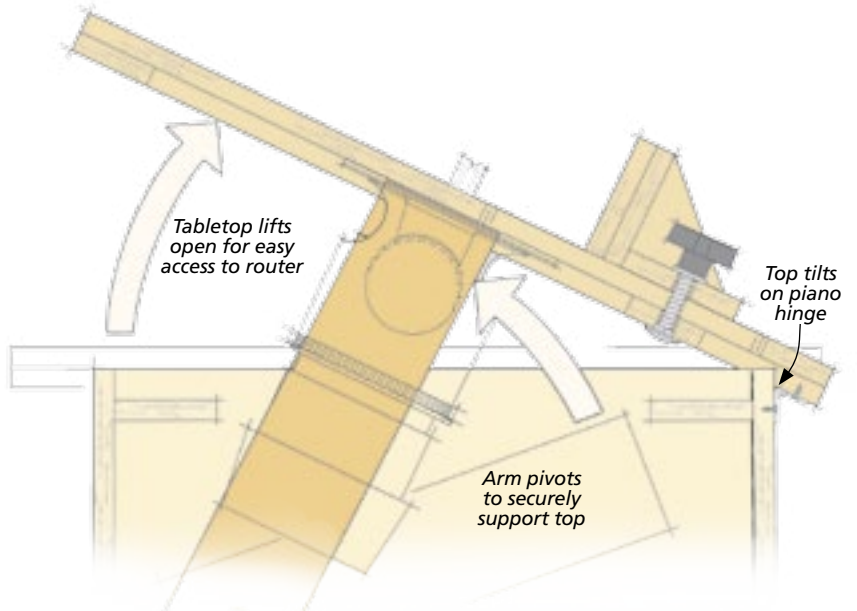

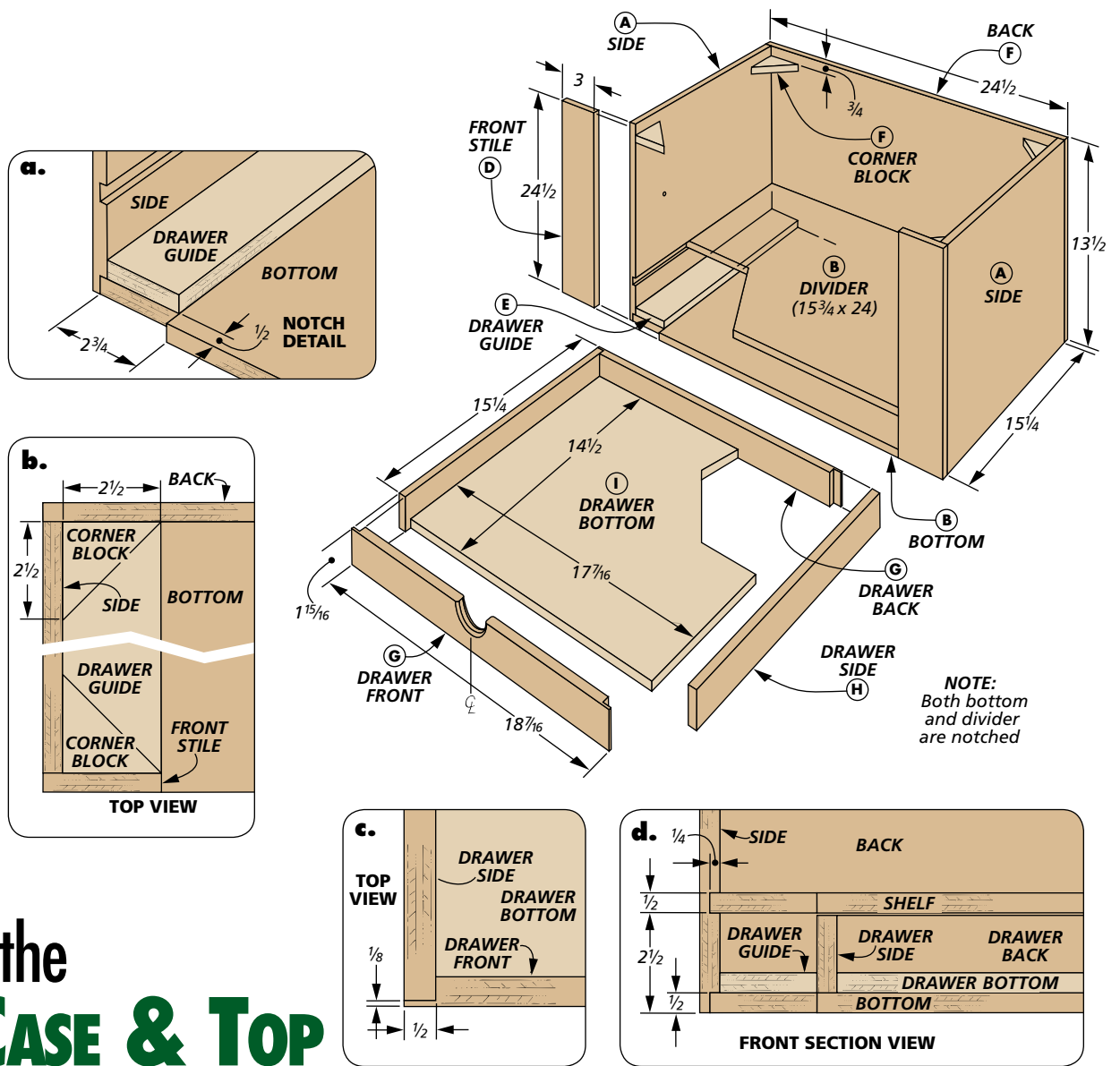

build the CASE & TOP

One of the goals I had when building the case of the router table was to make sure it could be built quickly. But it still needed to be strong enough for every day use.

STRAIGHTFORWARD JOINERY. As I mentioned earlier, the router table case uses sturdy plywood construction with dados and rabbets. The whole table is built from 1/2" plywood. (I used Baltic birch.)

SIDES FIRST. I began by constructing the case sides. In detail 'd', you can see that there's a dado and a rabbet cut in each side piece. This joinery locks a divider and the case bottom in place for a super strong, wobble-free assembly. The divider also creates a pocket for the drawer that will be added later.

Before assembling the divider and bottom to the sides, I cut a 2 3/4"-wide notch at the front corners of each

piece, as you can see in Figure 1a. These notches hold a pair of narrow stiles that keep the front of the case rigid while still providing a large opening for access to the router.

The back is a simple plywood panel that's sized to overlap the sides. With these main parts cut, you can glue and clamp the case together.

CORNER BLOCKS. The divider and case bottom make the lower portion of the case plenty strong. But since the tabletop isn't screwed to the case, the upper part of the case needs some reinforcement.

The solution I used here was to make four, angled corner blocks, as illustrated in detail 'b.' You can see in the main drawing that I positioned them 3/4" from the top edge of the case. The reason for this is simple. The hinged tabletop is designed to nestle down over the top of the case,

so lowering the corner blocks ensures that they won't interfere with the fit.

There are just two parts left to add to the case before moving on to the drawer. And those are a pair of drawer guides. They're cut to fit behind the front stiles to keep the drawer from binding in the opening, as shown in detail 'd.'

SIMPLE DRAWER. The drawer in the router table provides a place to store wrenches, bits, and other supplies. And like the rest of the router table, it's straightforward to build.

In the drawing above, you can see that a rabbeted frame simply wraps around the drawer bottom. The relatively thick bottom provides plenty of glue surface for a strong bond.

LARGE, FLAT TOP. With the case complete, I set it aside and turned my attention to the top, shown in the drawing on the next page.



► **Tilt-Up Top.** The top is attached with a piano hinge. This allows easy access to the router without having to bend over.

Since this is where all the work will take place after the table is complete, the goal here is to make the top as flat and rigid as possible.

Making a large top from plywood isn't a challenge — just cut it to size. But with 1/2" plywood, you want to make sure it won't flex under the load of large, heavy pieces. So, to make this tabletop stay flat, it's reinforced around the bottom edge.

The top has a few openings cut into it. In the center is a hole that serves as the opening for router bits. At 2" in

diameter, it's plenty big enough to handle most common bit sizes. To attach the router to the table, I simply screwed it to the top.

The other two openings are a pair of slots that will be used to connect and adjust the fence that will be added later, as in drawing below.

FILLERS AND BRACES. As I mentioned, the top is strengthened by attaching cleats to the underside. Besides keeping the top from flexing, the cleats also serve another purpose. They are positioned so that the top

fits over the case like a lid. You can see this in Figures 2a and 2b.

TILT-TOP DESIGN. Rather than screwing the top to the case, I attached it with a piano hinge along the back edge. This allows me to tilt up the tabletop and get at the router to change the bit height — without having to stoop over.

Then, to hold the top open so I can use both hands, I bolted a prop arm to the inside of the case with a carriage bolt, nut, and washer, as shown in the drawing and arm detail below.

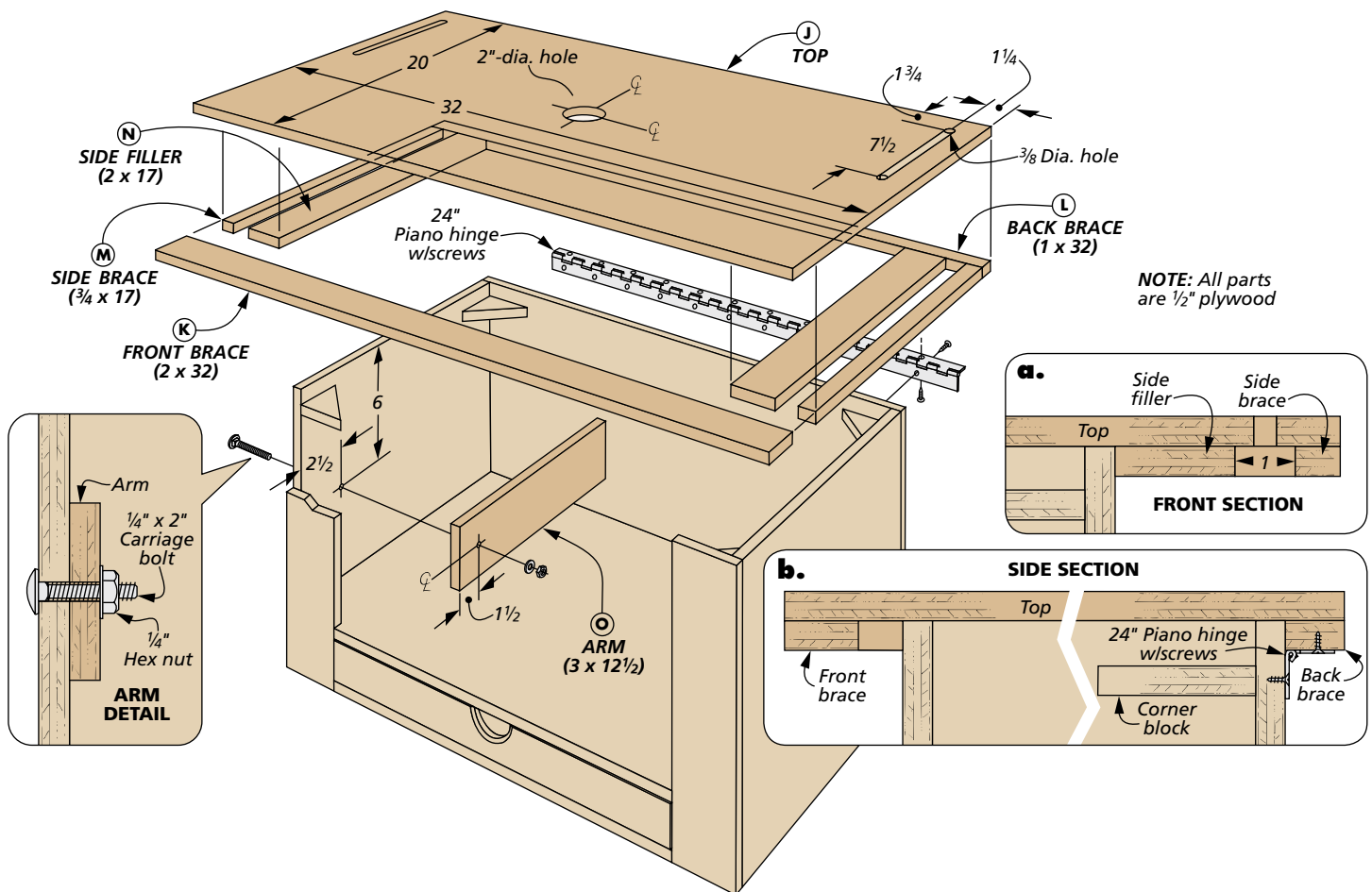

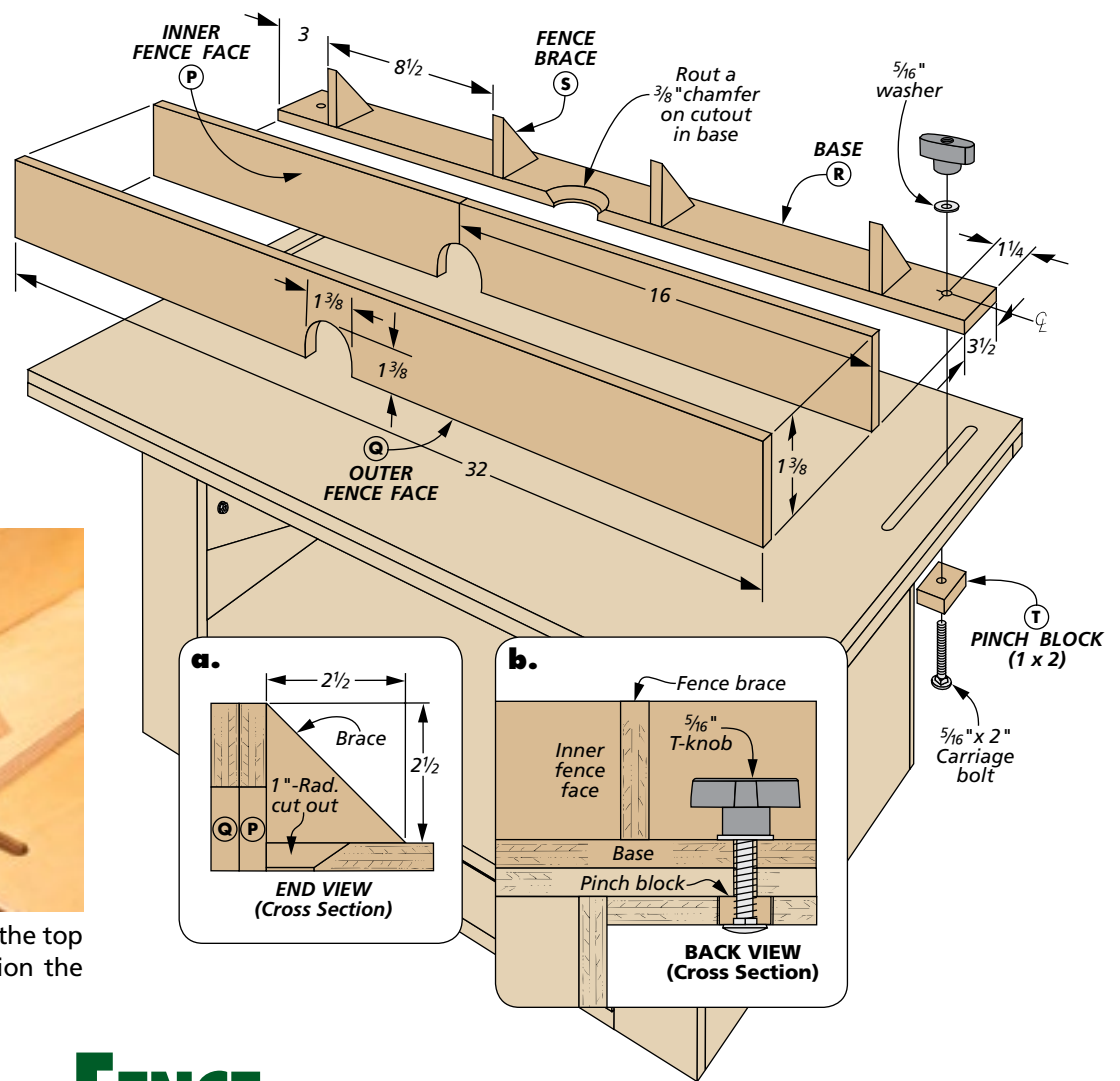

▲ Router Fence. Grooves in the top allow you to easily position the fence and lock it.

a precision FENCE

The last assembly to build to complete the router table is the fence, as shown in the drawing above. And it's really what transforms the router table into a precision tool you'll come to rely on.

For the fence to work its best, it needs to do three things. First, the fence needs to be rigid so it won't deflect as a workpiece slides across it. Second, the fence face has to be square to the tabletop. This way, you can be sure your cuts are accurate every time. Finally, it has to lock securely to the tabletop.

HEAVY-DUTY FACE. The first step in building the fence is to make the faces. Here, I used a double-layer fence assembly. The added layer of 1/2" plywood makes it less likely to flex or warp over time. A centered cutout in each layer is large enough to accommodate most router bits.

You'll notice the inside face of the fence is made from two pieces. I did this in order to get all the parts from a single sheet of plywood.

STABLE BASE. This assembly is then glued to the front of a base that has a matching cutout. To help

dust and chips clear this opening, I routed a chamfer on the cutout in the base (Figure 3a). To reinforce the joint between the fence and the base, I glued braces to the base and the backside of the fence face.

ATTACHING THE FENCE. The fence is connected to the table with carriage bolts, washers, and knobs. A pair of pinch blocks slide in the channel created by the brace and filler on the bottom side of the table.

Once the fence is attached to the table, all you have to do is plug in your router and get to work. **W**