

Mill uniform widths with your planer

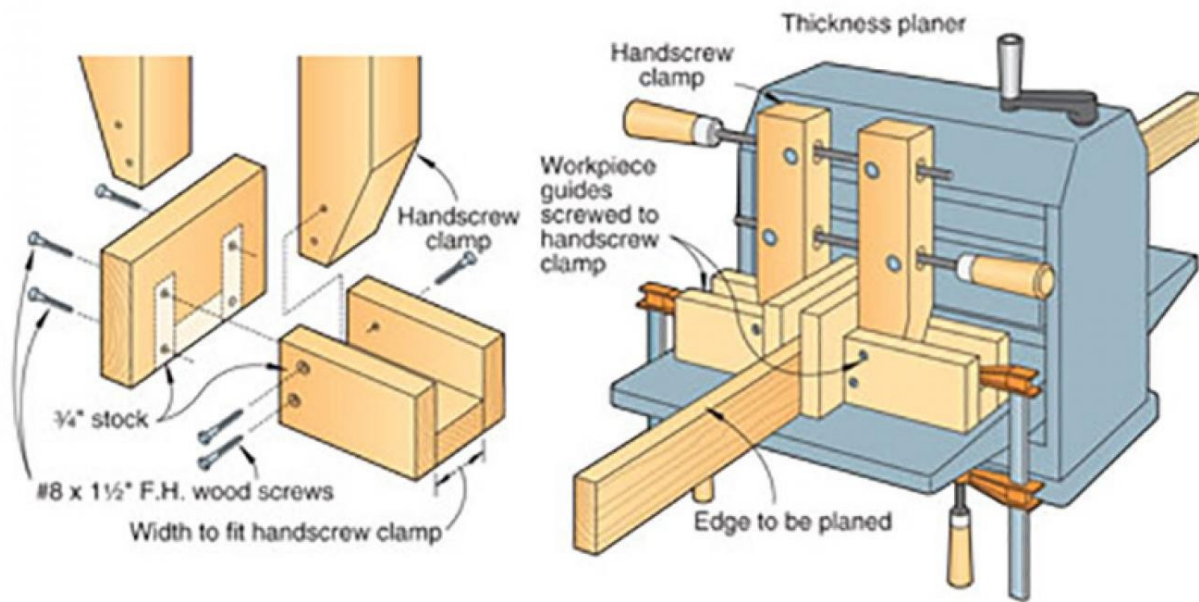

With an old handscrew clamp and some scraps of hardwood, you can set up your thickness planer to mill uniform-width door or cabinet stiles, rails, and other pieces with jointer-smooth, square edges.

Prepare your workpieces by jointing one edge and ripping the other edge so the workpieces are slightly too wide. Then, clamp one of the workpiece guides to your planer's infeed table and adjust its face 90° to the planer table. Adjust the face of the opposite guide so the part fits snugly between the guides. Clamp down the other guide. Fine-tune the snugness of the guides on the workpiece with a handscrew clamp.