

How to grain-wrap a box

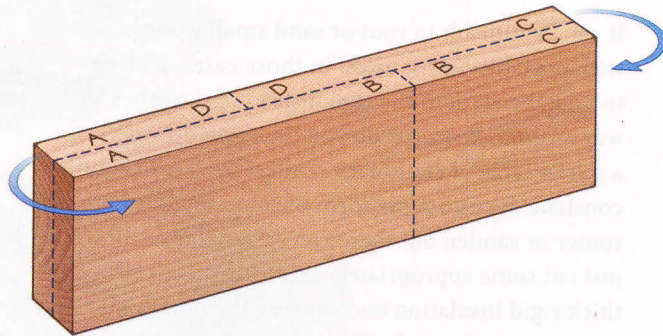

Step 1: Label edges, resaw, then flop boards and mark miters.

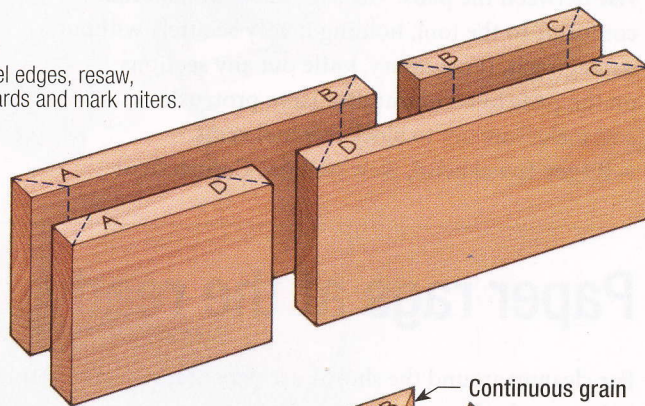

Step 2: Miter ends. Join matching corners.

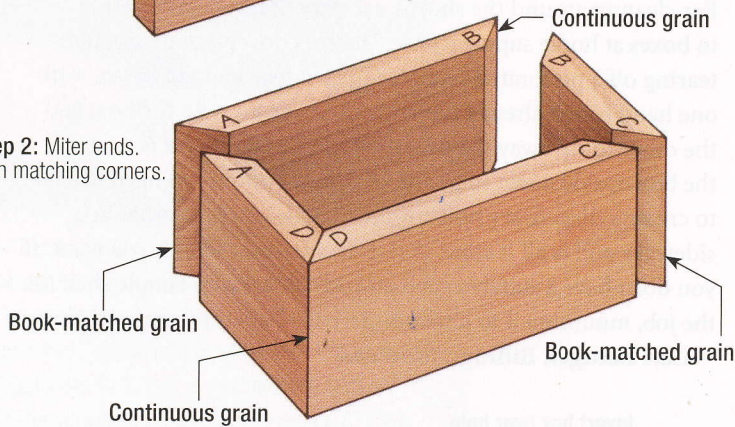

A mitered box looks best when the grain runs uninterrupted around the corners. To perform this trick, begin with stock that's twice the desired thickness of your finished wall, plus $\frac{1}{4}$ " or so for milling. Rip it to finished width, and about $\frac{1}{4}$ " longer than the combined length of 2 contiguous walls. Lay the walls out to length in the order shown in the top drawing, lettering the individual parts for reorientation later. After resawing the stock, plane it to final thickness, and then cut the pieces to length. To lay out the miters, first swap the pieces as shown in the top 2 drawings, which effectively turns the blank inside-out. After cutting the miters and joining the letter-matched ends, one pair of diagonally opposed box corners will exhibit continuous grain, and the opposite corners will be book-matched. Nice!

—Geoffrey Noden, Trenton, New Jersey